



Hitec 2.4GHz Telemetry Displays

HITEC TX



ECLIPSE 7 AURORA 9



Cockpit View Screen
No more guessing, see the necessary information in real-time

SPECTRA 2.4



HTS-IVIEW
Telemetry mobile interface



HTS-VOICE
Telemetry voice announcement



HPP-22
Telemetry PC interface



HTS-NAVI
Wireless Telemetry Receiver



Tip TIP: The above telemetry interface systems can be used with any brand of transmitter that is compatible with a Spectra 2.4 module.

Battery Installation Method

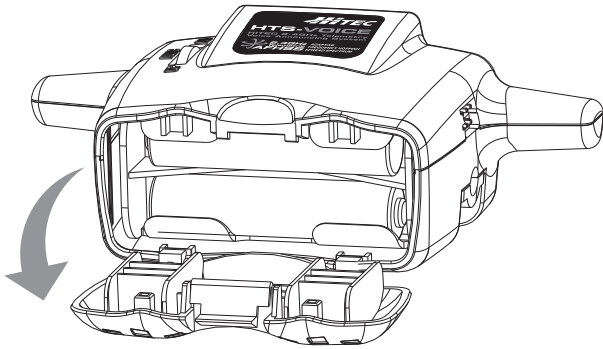

Open the battery cover of the HTS-VOICE and insert two AAA alkaline batteries.

! Alkaline batteries are strongly recommended. If rechargeable batteries are used (NiCd or NiMH), a premature battery warning may occur.

Installation

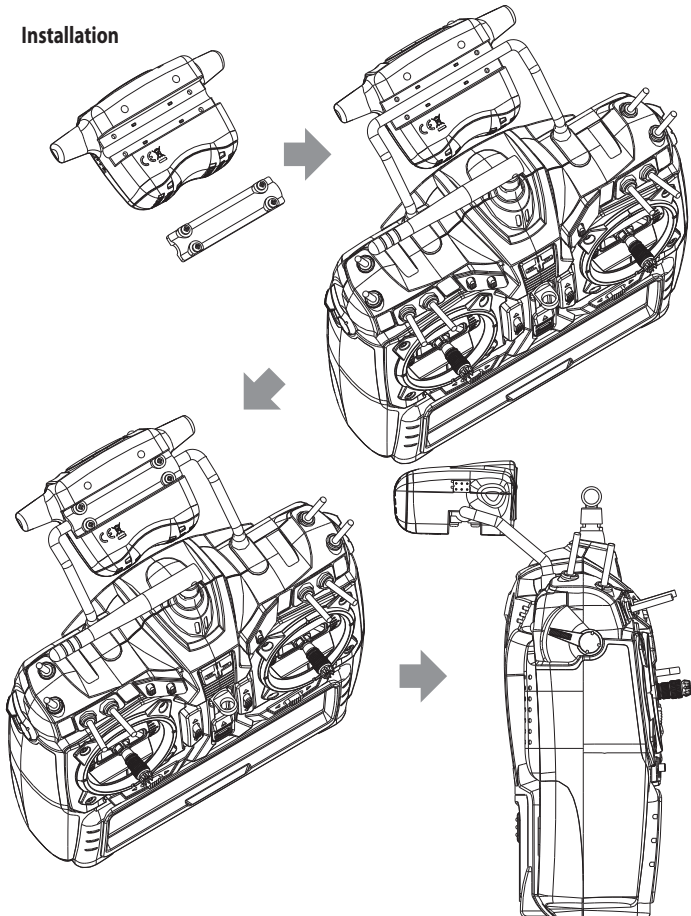

1. With a #1 or 4mm Philips screwdriver, remove the four screws holding the small brace from the case of the HTS-VOICE.
2. Clip the HTS-VOICE to the handle of the transmitter.
3. Place the small brace back onto the HTS-VOICE and loosely screw back into place so that you can adjust the HTS-VOICE speaker to the desired location.
4. Tighten the four screws to secure the position.

Connection with the Transmitter

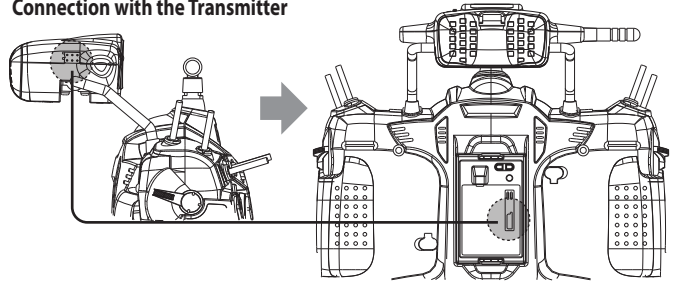

1. Connect one side of the 3-pin connector cable (included in this package) with one of the two ports on the HTS-VOICE.
2. Connect the other side of the 3-pin connector cable with the transmitter's data port.
3. Press and hold the function button to turn on the power to the HTS-VOICE. The LED will light when the power is on.
4. Turn the transmitter on and now turn the receiver (Optima series) on.
5. The voice announcing from the HTS-VOICE will start shortly.

! Two function ports are located on the side of the HTS-VOICE and share the same function. Choose one to connect with the transmitter, the HPP-22 or HTS-IVIEW.

If you use the HTS-VOICE without an HTS-SS sensor station (either Nitro or Blue), only basic telemetry data (battery receiver and SPC voltage) will be announced.

An Optima 7 or Optima 9 receiver with a data port is required in order to operate the HTS-SS series (either Nitro or Blue).

Please note that a small time delay occurs between the time the transmitter receives data and it is announced through the HTS-VOICE.

Enter the Set-up Mode

When the power to the HTS-VOICE is off, push the function button up until the LED light is on, you are now in set-up mode. The HTS-VOICE will start to announce the set-up information in order. You can now change each set-up to your preferences.

Description for each Set-up Mode

Once you are in the set-up mode, each function will be announced through the HTS-VOICE in the order below. You can set each function to your preferences (see options below).

(Sound)	FUNC	(Sound)	Set up Mode
UP		DN	Func : Select
			UP : Previous Step
			DN : Next Step

1. Unit Selection Set-Up

- [Imperial - Mode] : Selects announcing speed and temperature data as MPH and °F
- [Metric - Mode] : Selects announcing speed and temperature data as KM/H and °C

2. Announcing Time Delay Set-up

- [Chattering - Mode] : Announces data values continuously without a time interval
- [10 Sec. Delay - Mode] : Announces each data value at 10 second time intervals
- [30 Sec. Delay - Mode] : Announces each data value at 30 second time intervals

3. Current Setting Mode

- [YES] : Choose to enter the Current Setting Mode
- [No] : Choose to NOT enter the Current Setting Mode and to finish the Set-Up Mode

! If your plane is installed with an HTS-SS Blue, choose YES in the Current Setting Mode so the HTS-VOICE will announce the current, voltage and wattage data.

4. Current Set-up

- [C-50] : This set-up is dedicated to the current sensor C-50 (50A) used with the HTS-SS Blue
- [C-200] : This set-up is dedicated to the current sensor C-200 (200A) used with the HTS-SS Blue

! If are you using a current sensor with a different value than the two mentioned above, a malfunction could occur.

5. Voice Battery Warning

When the voltage of the AAA-size alkaline batteries drops under the required operation voltage, a warning will be announced through the HTS-VOICE.

! The set-up of the Voice Battery Warning cannot be changed to your preferences at this time; however, you will be able to change it in the future using a new PC program.