

## 8. Troubleshooting Guide

**Question:** I installed the batteries in my transmitter, but the power lights do not come on:

**Answer:**

- Check that the batteries are properly installed by checking the polarity (+ and -).

**Question:** My radio has power, but I have no control:

**Answers:**

- Check to be sure the power switch is on and connected to the receiver.
- Make sure the batteries are charged (Replace or recharge if needed.)
- Make sure you are using the proper crystals.

**Question:** My vehicle is glitching, or the servos and/or speed control is acting erratically:

**Answers:**

- Check that there are no radios operating on your channel.
- Make sure your electric motor has capacitors and the comutator is clean and brushes are not worn out. Replace if needed.
- Check for loose screws as metal-to-metal contact can cause interference.
- Make sure your receiver antenna has not been damaged or cut.
- Make sure the power wires are at least 2" away from the receiver.
- Replace the crystals if needed.
- If all fails, send the system in to be serviced, as there may be internal damage.

## 9. Warnings

- Never operate your car or truck in a crowded street with traffic.
- Always extend your transmitter antenna when in operation.
- Always check the battery power indicator before use.
- Do not operate two or more models on the same frequency at the same time.
- Do not operate your model in the rain or run through standing water.
- Do not operate your model within one mile of a radio control racetrack.
- Do not operate your model while under the influence of drugs or alcohol.
- Always turn on your transmitter first and then the receiver to prevent loss of control.
- When collapsing your antenna, never push it from the top or it may bend.

## 10. Racers Tips

- Slower is faster, Do not overdrive your car. A cleaner line around the track is faster than more top speed. Don't overshoot the corners.
- Reduce your steering dual rate if your car is over-steering or "Loose", and increase the rate if your car is under-steering or "Pushing."
- Add more drag brake (see Steering and Throttle trims) if your vehicle is "Pushing" into the corners. Move the trim the other direction so your car creeps forward slightly when the throttle is at neutral if your car is "Loose" when entering the corners.
- Don't crash! It's better to take a more conservative line than flip over and have to have a turn marshal turn you back over.
- The most important thing to remember is to have fun!

CE 06810

Austria, Belgium, Denmark, Finland,  
 France, Germany, Greece, Iceland,  
 Ireland, The Netherland, Italy, Spain,  
 Norway, Portugal, United Kingdom,  
 Luxembourg, Sweden, Switzerland

## INSTRUCTION MANUAL



LCD Display

RF LED

Sub-Trims

Dual Rate Steering

Exponential

10 Model Memory

4 Character Model Naming

Quick Response 1024 Step Resolution

Dual Mode 3rd Channel Shift or Linear

And More!

## Table of Contents

Page 2	<b>1. System Features</b> <input type="checkbox"/> A. Radio Features <input type="checkbox"/> B. Programmable Features
Page 3	<input type="checkbox"/> C. System Specifications <input type="checkbox"/> 1. Transmitter <input type="checkbox"/> 2. Receiver <input type="checkbox"/> 3. Servo <input type="checkbox"/> 4. Accessories <input type="checkbox"/> 5. Options <input type="checkbox"/> 6. Available Versions
Page 4	<b>2. Transmitter Functions and Operations</b> <input type="checkbox"/> A. Power Switch <input type="checkbox"/> B. LCD Display <input type="checkbox"/> C. Programming Buttons
Page 5	<input type="checkbox"/> D. RF Indicator Light <input type="checkbox"/> E. Steering Dual Rate <input type="checkbox"/> F. ATL Switch <input type="checkbox"/> G. Steering and Throttle Trims <input type="checkbox"/> H. Third Channel Linear Adjust <input type="checkbox"/> I. Third Channel (Shift) Button <input type="checkbox"/> J. Battery Cover
Page 6	<input type="checkbox"/> K. Antenna <input type="checkbox"/> L. Grip Pad <input type="checkbox"/> M. Module <input type="checkbox"/> N. Charging Jack <input type="checkbox"/> O. Steering Wheel <input type="checkbox"/> P. Capital Tension <input type="checkbox"/> Q. Throttle Trigger <input type="checkbox"/> R. Brake Limiter
Page 7	<b>3. Transmitter Functions and Operations</b> <b>4. Recharging Batteries</b>
Page 8	<b>5. Receiver Servo Connections</b> <input type="checkbox"/> A. Receiver
Page 9	<input type="checkbox"/> B. Servos <input type="checkbox"/> C. Battery
Page 10	<b>6. Main Edit Mode</b> <input type="checkbox"/> A. Entering the Main Edit Mode <input type="checkbox"/> B. Model Naming <input type="checkbox"/> C. Model Copy
Page 11	<input type="checkbox"/> D. Model Reset <input type="checkbox"/> E. Servo Reversing <input type="checkbox"/> F. Timer
Page 12	<b>7. Programming Mode</b> <input type="checkbox"/> A. Model Select <input type="checkbox"/> B. Sub-Trims
Page 13	<input type="checkbox"/> C. EPA (End Point Adjustment)
Page 14	<input type="checkbox"/> D. Exponential <input type="checkbox"/> E. Radio
Page 15	<b>8. Troubleshooting Guide</b> <b>9. Warnings</b> <b>10. Racers Tips</b>

## Introduction

Congratulations on your purchase of the Hitec Aggressor SRX computer radio. The Aggressor SRX is loaded with many great features to maximum your R/C experience. Please read this manual carefully to familiarize yourself with the operation of your new Aggressor SRX Computer Radio System.

## 1. System Features

### A) Radio Features

- Ergonomically Designed 3-Channel Pistol Grip FM Computer Radio System
- Multi-Pixel LCD Display
- Removable Module for Easy Channel Changing (Spectra Compatible)
- Dual Rate Steering (Adjustable on the Fly)
- Brake ATL Switch (Adjustable Travel Length)
- Brake Lever Travel Limiter
- Steering Wheel Tension Adjustment
- Digital Trims
- Trim Center Audible Verification
- Third Channel "Shifting" Button
- Third Channel "Linear" Digital Trim
- Interchangeable Assorted Color Rubber Grip Pads in Two Sizes (Sold Separately)
- Foam Steering Wheel for Comfortable Control
- Transmitter Charging Jack for Optional Rechargeable Batteries
- Green RF (Radio Frequency) Indicator Light
- Two-Speed Menu Scrolling
- Transmitter Low Battery Alarm

### B) Programmable Features

- Model Naming (4 Characters)
- Model Select (10 models)
- Sub-Trims
- Ch #3 Switch Set (Shift or Linear)
- End Point Adjustment (EPA)
- Exponential Travel (Steering and Throttle)
- Timer
- Servo Reversing
- Model Reset (Factory Default)



Transmitter

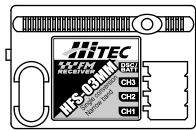

Receiver

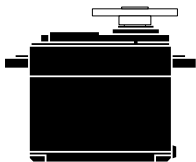

Servo

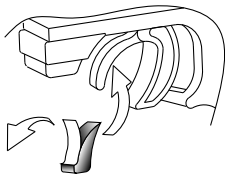

Accessories (Brake pad)

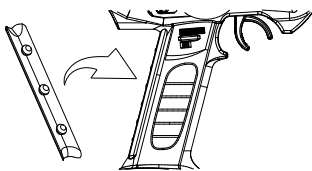

Option (Grip pad)

### C) System Specifications

#### 1. Transmitter

- Power Output: 300mW
- Capital Drain 180mA
- Modulation: FM
- Power Supply: 8AA Alkaline, NiCad or NiMh Batteries
- Frequencies: 27mhz (6 channels), 75mhz (30 channels) USA

#### 2. Receiver

- HFS-03MM
- Modulation: FM, Single Conversion
- Power Supply: 4.8V- 6V
- Weight: 0.56oz
- Size: 1.5"x1.0"x 0.6"
- Current Drain: 30mA +/- 0.3mA

#### 3. Servo

- |  |   |
|--|---|
| <input type="checkbox"/> - HS-311                                      | <input type="checkbox"/> - HS-645MG                                     |
| <input type="checkbox"/> - One Resin Bushing                           | <input type="checkbox"/> - Dual Ball Bearing                            |
| <input type="checkbox"/> - Hitec Custom I.C                            | <input type="checkbox"/> - Metal Gears                                  |
| <input type="checkbox"/> - Operating Speed : 0.15 sec AT 6v            | <input type="checkbox"/> - Operating Speed : 0.2 sec AT 6v              |
| <input type="checkbox"/> - Output Torque : 51 oz.in AT 6v              | <input type="checkbox"/> - Output Torque : 133 oz.in AT 6v              |
| <input type="checkbox"/> - Weight : 43g(1.5oz)                         | <input type="checkbox"/> - Weight : 55.2g(1.9oz)                        |
| <input type="checkbox"/> - Size : 40 X 20 X 37mm<br>(1.6 X 0.8 X 1.4") | <input type="checkbox"/> - Size : 41 X 20 X 38mm<br>(1.6 X 0.8 X 1.48") |

#### 4. Accessories

- **Brake pad** : This small piece of foam can be attached to the brake lever to take up any space between it and your finger for a custom fit.

#### 5. Options

- **Grip pads**: Blue, Red, and Black
  - (Small Part # 54309 / Large Part# 54310)
- 1600 mAh NiMh Battery: Part# 54114
- Overnight Wall Charger: Part#43025

#### 6. Available Versions

- Standard**: Part# 129271 (27 MHz)
  - Description: SRX Transmitter, HFS-03MM Receiver,
  - (1) HS-311 servo, Alkaline Battery Tray.
- Standard**: Part# 129751 (75 MHz)
  - Description: SRX Transmitter, HFS-03MM Receiver,
  - (1) HS-311 servo, Alkaline Battery Tray.
- Deluxe**: Part# 129752 (75 MHz only)
  - Description: SRX Transmitter, HFS-03MM Receiver,
  - (1) HS-645MG Heavy Duty servo, Alkaline Battery Tray.
- No Servos**: Part# 129753 (75MHz only)
  - Description: SRX Transmitter, HFS-03MM Receiver,
  - Alkaline Battery Tray.

## 2. Transmitter Functions and Operations

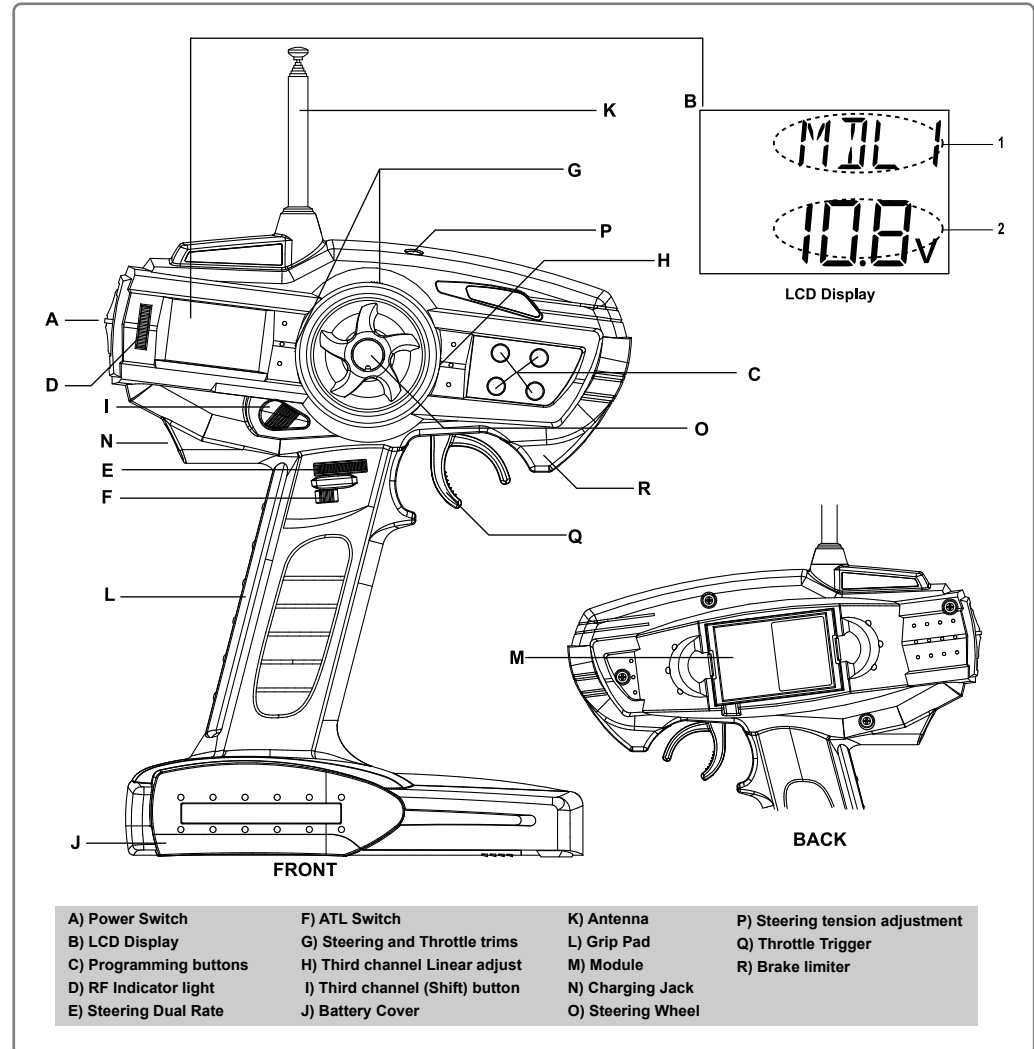

A) Power Switch	F) ATL Switch	K) Antenna	P) Steering tension adjustment
B) LCD Display	G) Steering and Throttle trims	L) Grip Pad	Q) Throttle Trigger
C) Programming buttons	H) Third channel Linear adjust	M) Module	R) Brake limiter
D) RF Indicator light	I) Third channel (Shift) button	N) Charging Jack	
E) Steering Dual Rate	J) Battery Cover	O) Steering Wheel	

#### A) Power Switch

- Slide the switch up to turn the transmitter on, and down to turn it off.
- **Warning: Always turn your transmitter on first and off last to prevent accidental runaways.**

#### B) LCD Display

1. Model Name
2. Battery voltage & meter

#### C) Programming buttons

- Top left : Function
- Bottom left : Select
- Top right : Data "+"
- Bottom right : Data "-"

#### D) Radio Frequency (RF) Indicator Light

- The green light will only be on if the transmitter is sending a signal.

#### E) Steering Dual Rate

- Adjusts the overall travel of the steering servo.
- Push the dial forward with your thumb for maximum steering (Maximum 125%).
- Pull the dial back with your thumb to reduce the travel (Minimum 60%).
- Use this to fine tune your vehicles handling for the surface conditions.
- Use more steering travel for high bite surfaces and less for low bite surfaces.

#### F) Actual Travel Length (ATL) Switch

- Adjusts the brake servo or ESC (Electronic Speed Control) travel end point.
- Push the switch forward with your thumb for maximum braking (Maximum 125%).
- Pull it back to reduce the braking power (Minimum 0%).
- **Note: Be aware that at 0% you will have no brakes.**

#### G) Steering and Throttle Trims

- These trims are used to fine-tune the point where the servo returns to center.
- Adjust the ST-TRIM so your vehicle travels perfectly straight when the steering wheel is centered.
- **Note: If you move the trim to its maximum and the vehicle does not go straight, move the servo horn on the servo output spline or adjust the sub-trim to fix the problem.**
- Use the THR-TRIM to adjust the "Drag Brake" or "Coast Brake"; this is the amount of braking that occurs when the trigger is at neutral.
- **Tip#1: Do not mount the horn on the servo until you turn on the radio and center the trims and sub-trims.**
- **Tip#2: Always check your trims before you drive or race.**

#### H) Third Channel Linear Adjust

- Used to adjust the AUX servo to any position.
- **Note: This feature is typically used for a mixture control in nitro boats.**

#### I) Third Channel (Shift) Button

- Use to shift gears in vehicles like the T-Maxx® and others.
- Pushing the button will move the AUX channel servo from one end of its travel to the other (-100% to +100%).
- **Note: You can adjust the overall travel with the AUX EPA (End Point Adjustment)**

#### J) Battery Cover

- Remove to change or remove the batteries.

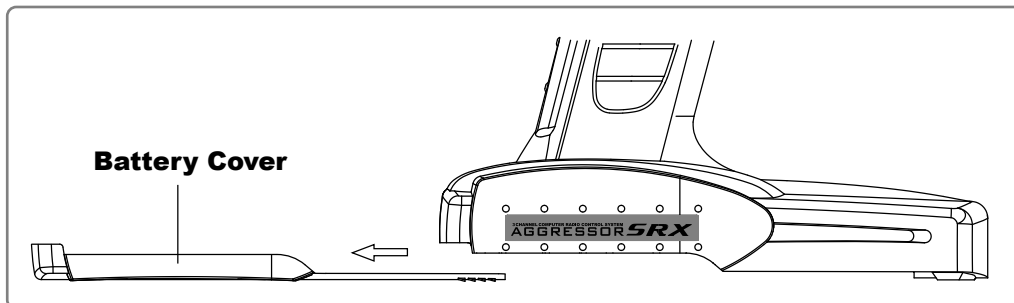

#### K) Antenna

- Always extend your antenna before turning your transmitter on.
- The antenna may be removed by turning counter clockwise.
- **Warning: When collapsing your antenna, never push it from the top; it may bend.**

#### L) Grip Pad

- The removable grip pad helps keep your hand secure on the radios pistol grip handle.
- The Grip Pads are available in assorted colors and sizes to customize the look and feel of your radio.

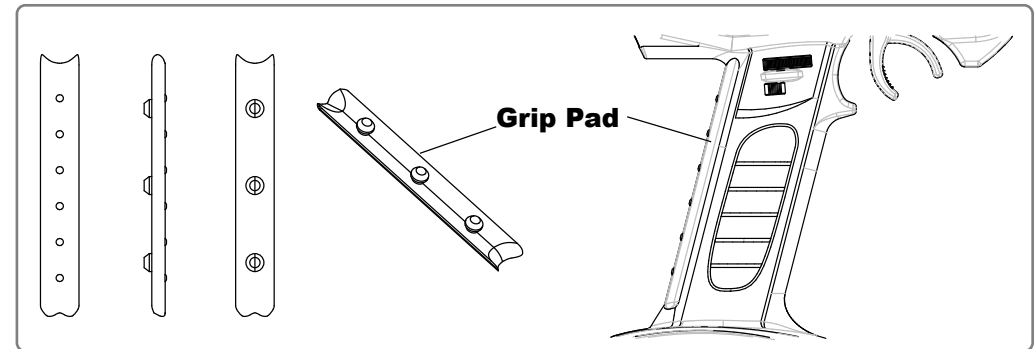

#### M) Module

- The replaceable module located in the back of the transmitter contains the frequency crystal and frequency band of the radio.
- Crystals may be interchanged if permitted.
- The Spectra synthesized module is available in certain radio system versions, or it can be purchased separately.
- The Spectra module will allow any channel to be selected within the 75MHz band.
- To remove the module, press the tabs with your thumb and finger while pulling it outward.
- **Note: Wiggle the module to help ease its removal.**

#### N) Charging Jack

- The transmitter charging jack located under the power switch is for use with the Hitec optional CG-25 charger. The charger can be purchased separately if using rechargeable batteries.
- (See "Recharging Batteries" for more information about this feature.)
- **Warning: Do not attempt to charge alkaline batteries; they may explode.**

#### O) Steering Wheel

- Used to control the steering of your vehicle.

#### P) Steering Tension Adjustment

- Used to tighten or loosen the tension of the steering wheel.

#### Q) Throttle Trigger

- Used to control the throttle and braking of your vehicle.
- Pull the trigger for throttle and push it forward for braking or reverse when using a reversing Electronic Speed Control.

#### R) Brake Limiter

- Used to limit the physical "braking travel" of the trigger.

### 3. Transmitter Battery installation

- Press down on the battery cover and slide in the direction illustrated.
- Remove the cover and install the batteries as shown.
- Remember to be careful and pay close attention to the polarity of each cell you could damage the transmitter.
- Replace the cover; making sure it is closed securely.

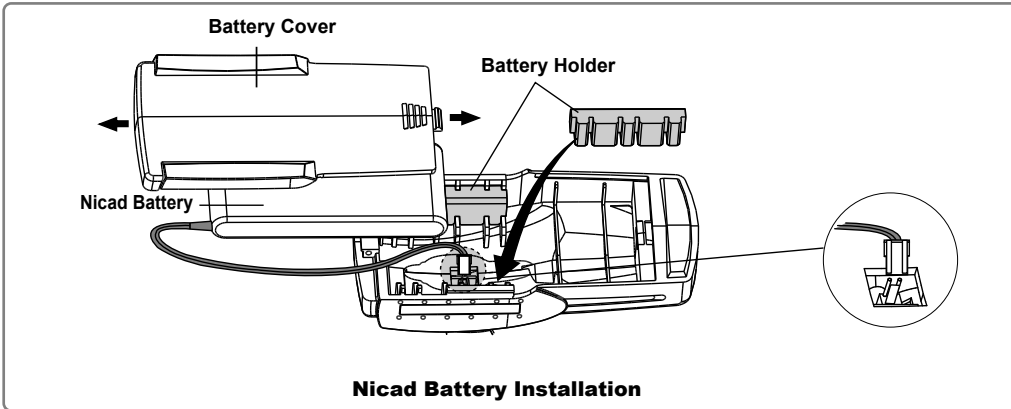
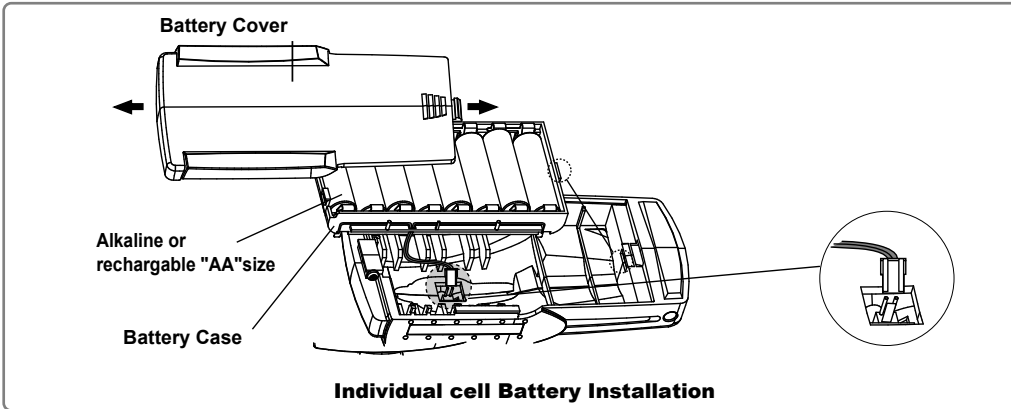

### 4. Recharging Batteries

- Connect the optional Hitec CG-25 overnight wall charger (sold separately) to the transmitter charging jack located under the transmitter power switch to charge optional re-chargeable batteries.
- **Note: If the charger is correctly hooked up to the transmitter, the red light on the charger will be lit while charging. If it is not, check the connection or the battery.**
- The CG-25 can also charge four (4) cell receiver batteries up to 1000 mAh through the other output pigtail of the charger. Simply plug the connector into the receiver battery pack or the charge port of the on/off switch if applicable.
- **Note: If the charger is correctly hooked up to the receiver battery, the green light on the charger will be lit while charging. If it is not, check the connection or the battery.**
- A full charge on the supplied transmitter Nicad battery pack will take 12-16 hours.
- **Warning: Do not attempt to charge alkaline batteries; they may explode.**

### 5. Receiver Servo Connections

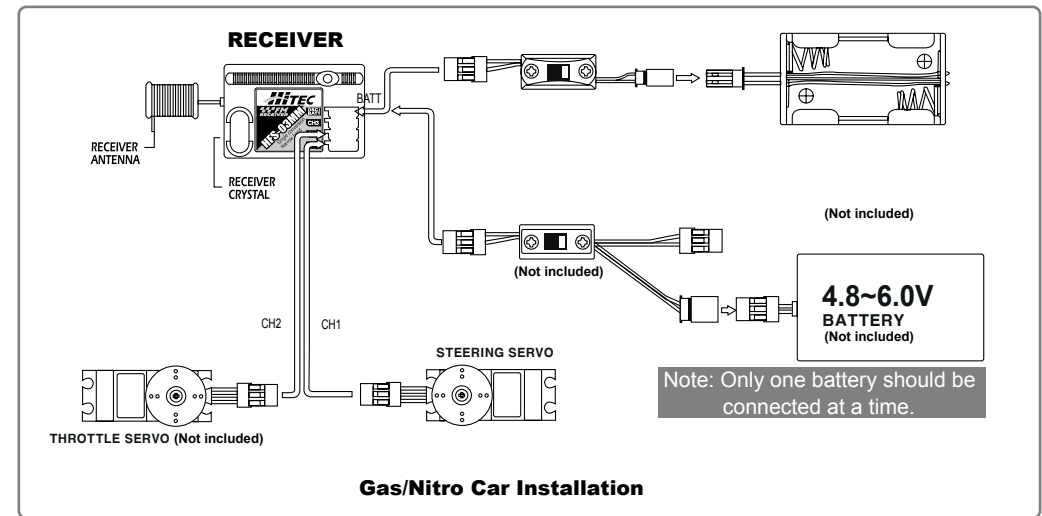
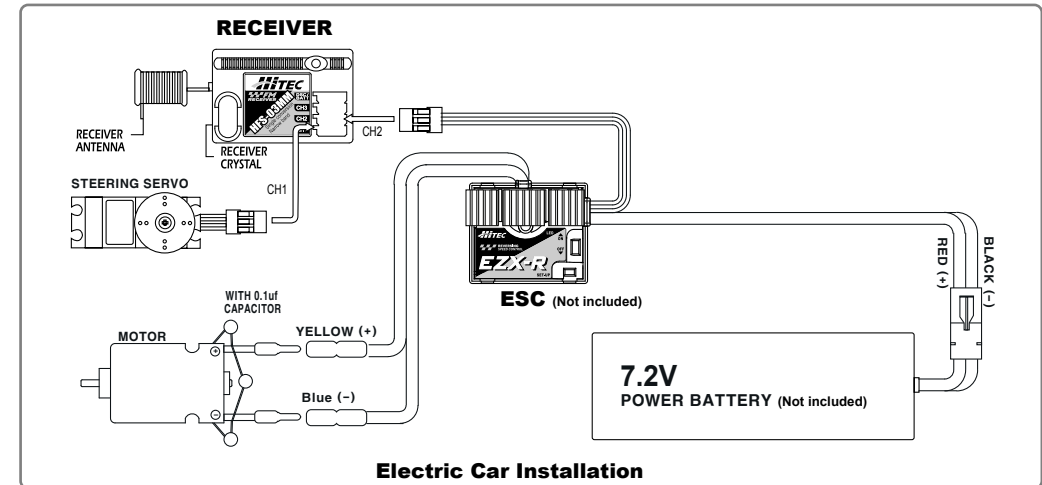

#### A) Receiver

- HFS-03MM Single Conversion
- You can use a separate receiver 4.8v - 6V battery pack if required for your particular model.
- This battery is typically only used with a gas or nitro powered vehicles to supply power to the receiver.
- Connect as shown.
- **Note: If using an electronic speed control, it will supply the power to the receiver through the connector plugged into channel #2.**
- Be aware you should keep your receiver antenna at least 2" away from any power wires to prevent potential interference.
- Route the antenna up an antenna tube as typically shown in your vehicles instructions.
- **Warning: Be sure not to cut off any excess antenna wire, as it will shorten your operating range.**

### B) Servos

- Your Aggressor SRX includes either an HS-311HD or a powerful HS-645MG high torque metal gear servo.
- The HS-311 is suited for light electric vehicles steering and most 1/10th size nitro vehicles for throttle.
- It should not be used for steering in nitro powered vehicles or heavy monster trucks.
- The HS-645MG is a high torque metal geared servo that is well suited for monster trucks and nitro powered vehicles.
- When installing the servos, refer to the manual of the vehicle for proper installation.
- Once your servos are correctly installed, make sure they are properly centered. To do this, remove the servo horns; turn on your transmitter, then the power to your receiver.
- **Note: Always remember to turn your transmitter on first and off last.**
- Failure to do so may result in loss of control and damage to your servos and/or linkage.**
- When the power is on, check to make sure the servos are working properly.
- Center the trim switches on the transmitter and replace the horns so that they are centered if necessary.
- Be aware the servos may not be perfectly centered. This is okay. Just get them as close as possible, and then use the trims or sub-trims for fine-tuning.

### C) Battery

- The AA receiver battery holder supplied with your radio should be used in a non-electric vehicle requiring two servos.
- Connect the AA Receiver battery holder or a 4 / 5 cell NiCad or NiMh pack to the power switch supplied, and then plug the switch harness into the "Batt" channel of the receiver for power
- You will not need this battery if you are using an electric car with an electronic or mechanical speed control with BEC.
- Ok! Now let's get to the programming!**

## 6. Main Edit mode

This menu allows you to set up the initial settings of the model, and will typically only be accessed once unless setting up a new model. The main edit mode screens will appear in the following order:

1. Model Naming
2. Model Reset
3. Channel 3 switch set
4. Timer

### Programming

#### A) Entering the Main Edit Mode

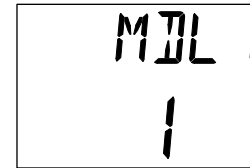

- Access the programming menu by holding the "FUNC" (function) button down, and then turning the transmitter power switch on. Release the function button.
- The model naming screen should appear.

#### B) Model Naming



- **Note: Be aware that you have to select the model you wish to name in the Programming mode first. (See Programming Mode [Model Select] to Select Desired Model)**
- Press the "DATA" + or - buttons to Select the proper letter or symbol.
- Press the "SEL" (Select) button to move the cursor.
- After the name is set, press the "FUNC" button to scroll to the next menu, or turn the transmitter off and back on to use the radio.

#### C) Model Reset

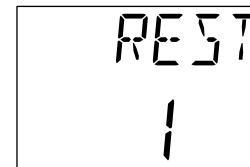

- After entering the Main Edit mode press the "FUNC" button to scroll to the Model Reset menu.
- To reset the model you are programming, press the "DATA" + and - buttons at the same time to complete the reset procedure.
- If properly done you will hear two "beeps".
- Be aware that all the settings will be reset to factory default, so anything previously set will be lost.
- Press the "FUNC" button to scroll to the next menu, or turn the transmitter off and back on to use the radio.

#### D) 3rd Channel Switch Select:

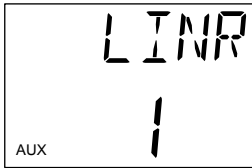

- After entering the Main Edit mode press the "FUNC" button to scroll to the 3rd Channel Switch Select menu.
- Push the "DATA" + and - buttons to Select either "Linear" or "Shift".
- Linear is activated via the trim tab on the right side of the steering column and can be moved to any position you select. This is typically used for mixture control in nitro boats, but you can use it for other functions if needed.
- Shift is activated by the momentary button located on the left of the steering wheel. This is used to shift vehicles such as the T-Maxx® or similar type vehicles.
- **#Tip: Use the knuckle of your left thumb to push the button to shift. When the button is pushed the AUX servo will travel to one end. When it is pushed again it will travel to the other end. This travel can be set in the EPA screen in the programming mode for fine tuning.**
- Press the "FUNC" button to scroll to the next menu, or turn the transmitter off and back on to use the radio.

#### E) Timer

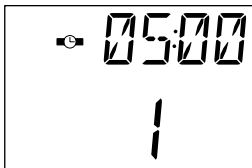

- After entering the Main Edit mode press the "FUNC" button to scroll to the Timer menu.
- Press the "SEL" button to move the cursor to select minutes. Time can be set from 01:00 up to 99:00 minutes.
- To activate the timer when using the radio, push the "SEL" button.
- To pause the timer, push the "SEL" button again; then, push it again to restart.
- To cancel the timer, push the "FUNC" button.
- **Note: When the timer reaches 00:10 seconds, you will hear a beep for each second counting down until it reaches 00:00.**
- Press the "FUNC" button to scroll to the next menu, or turn the transmitter off and back on to use the radio.

#### F) Exit

- Once you have set all the parameters in this menu you can exit by simply turning the radio off, and then back on again to operate.
- If there is still more programming needed push the "FUNC" button to scroll through the menu again.
- Scrolling only moves in one direction, so if you miss a screen, you must scroll through all of the menus until you get back to the screen you want.

## 7. Programming mode

This programming menu allows you to access the settings that you would typically change to set up your vehicle or change models. The Programming mode screens will appear in the following order:

1. Model Select
2. Sub-Trims
3. EPA
4. Exponential
5. Servo Reverse

### Programming

- Access the menu by holding the "FUNC" (function) button down for three seconds while the transmitter is already on.

#### A) Model Select



- Press the "DATA" + or - buttons to Select the model to be used. (1-10)
- **Note: Be aware that if you wish to name or re-name a model, you will need to turn the radio off, and then follow the model naming instructions in the main edit mode.**
- Press the "FUNC" button to scroll to the next menu, or press the "FUNC" button for three seconds to return to the operation screen.

#### B) Sub-Trims

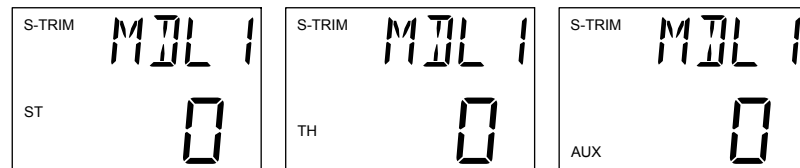

- After entering the Programming mode press the "FUNC" button to scroll to the Sub-Trim menu.
- ST "Steering" will appear first. Use the "DATA" + and - buttons to adjust the sub-trims right or left.
- Press the "SEL" button to access the TR "throttle" sub-trim and adjust with the "DATA" + or - buttons to adjust the sub-trims forward or back.
- Press the "SEL" button to access the AUX "Auxiliary" 3rd channel sub-trim and adjust with the "DATA" + or - buttons to adjust the sub-trims right or left.
- **Note: Push the "DATA" + & - buttons at the same time to reset to factory default.**
- Press the "FUNC" button to scroll to the next menu, or press the "FUNC" button for three seconds to return to the operation screen.

**C) EPA (End Point Adjustment)**

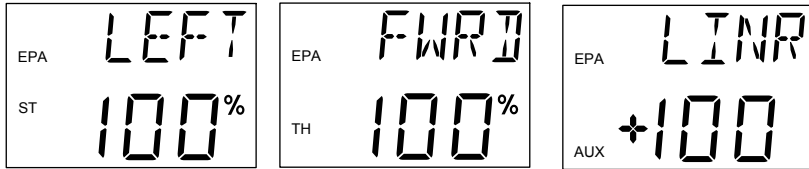

- After entering the Programming mode press the "FUNC" button to scroll to the EPA menu.
- The current settings will show on this menu.

**- STEERING EPA**

- "Steering" will appear first. Use the "DATA" + button to adjust the EPA setting higher or the - button to adjust it lower. The factory setting is 100%. You can increase the end points up to 125% or down to 0%.
- **Note: You have to adjust left and right separately; you must move the wheel in the direction you wish to set.**
- **Tip: Always max out the dual rate dial to 125% before setting your individual end points for maximum travel.**
- **Tip: The best way to set the EPA is to turn and hold the steering wheel to the left end, then increase or decrease the EPA so the servo moves the car's wheels or the boat's rudder to their maximum travel without binding. Repeat for the right side.**

**- THROTTLE EPA**

- Press the "SEL" button to get to the throttle EPA.
- To adjust the high throttle setting, pull and hold the trigger back.
- To adjust the Brake EPA push and hold the trigger forward.
- **Note: The ATL switch on the handle under the D/R dial will make the same adjustment as the Brake EPA.**
- **Tip: The ATL can be adjusted on the fly for fine tuning the braking power of the vehicle, and the current setting is displayed on the operating screen.**

**- AUXILIARY EPA "SHIFT"**

- Press the "SEL" button to get to the "AUX" Auxiliary 3rd Channel EPA.
- If "SHIFT" was selected for this model, you will need to push the shift button to set each side of the travel.

**- AUXILIARY EPA "LINEAR"**

- Press the "SEL" button to get to the Auxiliary 3rd Channel EPA.
- **Note: If "LINEAR" was selected for this model, you will need to move the AUX digital trim tab on the right side of the steering column to the side you wish to set. Leaving the trim centered will adjust both sides at once.**
- Press the "SEL" button to loop back to the main EPA menu.
- **Note: The main EPA menu will now show all the new settings.**
- **Note: Push the "DATA" + & - buttons at the same time to reset to factory default.**
- Press the "FUNC" button to scroll to the next menu, or press the "FUNC" button for three seconds to return to the operation screen.

**D) Exponential**

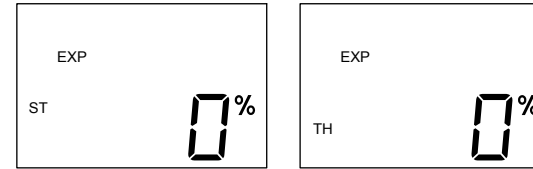

- Negative steering exponential will make the vehicle less sensitive to small inputs and Positive expo will make the vehicle more sensitive. Typically you will only use negative expo for steering but you should experiment with this setting to see what suits your driving style the best. -30% is a good place to start.
- Use negative expo for the throttle to broaden the power band and positive expo to increase the "punch". Typically you will use negative expo with a modified electric vehicle, nitro vehicle, or in situation where the traction is low and positive with a stock electric or when the traction is high.
- After entering the Programming mode press the "FUNC" button to scroll to the Exponential menu.
- Steering will show first.
- Press the "DATA" + button for positive Expo or the - button for negative expo.
- To adjust Throttle Exponential, press the "SEL" button once.
- Press the "DATA" + button for positive Expo or the - button for negative expo.
- **Note: Push the "DATA" + & - buttons at the same time to reset to factory default.**
- Press the "FUNC" button to scroll to the next menu, or press the "FUNC" button for three seconds to return to the operation screen.

**E) Servo Reversing**



- After entering the Main Edit mode press the "FUNC" button to scroll to the Servo Reversing menu.
- Steering will show first.
- Press the "SEL" button to move the cursor to select ST for steering, THRO for throttle or AUX for the third auxiliary channel.
- Once the proper channel is selected, press the "DATA" + and - buttons at the same time to reverse the servo.
- If properly done you will hear one "beep" and the display will change from "NOR" (Normal) to "REV" (Reverse) or vice versa.
- Press the "FUNC" button to scroll to the next menu, or press the "FUNC" button for three seconds to return to the operation screen.