

D845WP General Specification.

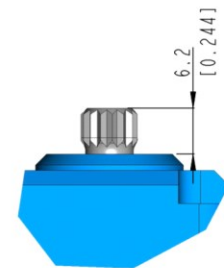

Control System	PWM/TTL(Half Duplex)			-
Position Sensor Type	Contact Analog Potentiometer			-
Motor Type	Cored Carbon Brush			At the Max voltage, it is recommended to be used only for a short time duration.
Operating Voltage Range	3.5 ~ 8.4V			
Voltage	4.8V	6.0V	7.4V	At 25°C(±10%), 45%RH(±10%) <u>measurement environment</u>
No Load Speed	0.26sec/60°	0.21sec/60°	0.17sec/60°	
Stall Torque	32.5kgf-cm (451.34oz-in)	40.5kgf-cm (562.44oz-in)	50.0kgf-cm (694.37oz-in)	
Peak Efficiency Torque	6.5kgf-cm (90.27oz-in)	8.1kgf-cm (112.49oz-in)	10.0kgf-cm (138.87oz-in)	
Standing Current	30mA	30mA	30mA	
No Load Running Current	1,100mA	1,250mA	1,600mA	
Stall Current	6,000mA	7,000mA	10,000mA	
Deadband	2μs	2μs	2μs	
Operating Travel	Default: ±60°, Programmable: Max 175° / Pulse Width: 900~2100μs(Center:1500μs)			-
Continuous Rotation	n/a			-
Operating Temperature Range	-20°C ~ +60°C (-4°F ~ +140°F)			-
Storage Temperature Range	-30°C ~ +80°C (-22°F ~ +176°F)			-
Connector Wire Length	300mm (11.811inch)			
Connector Wire Gauge	20AWG			
Dimensions	66.0mm x 32.0mm x 62.1mm (2.598inch x 1.260inch x 2.445inch)			General Tolerance ±0.1mm
Weight	227.0g (8.007oz)			Excluding the weight of Horn
Bearing Type	2 Ball Bearing			-
Case Material	Engineering Plastic & Aluminum Heat Sink			-
Gear Material	1 Metal-Plastic & 4 Steel Gears			-
Gear Train Backlash	Max 0.5°			-
Horn Gear Spline	15T(Ø8)			-
IP-Rating	IP67			-
Servo Amplifier Type	32bit programmable Digital			-

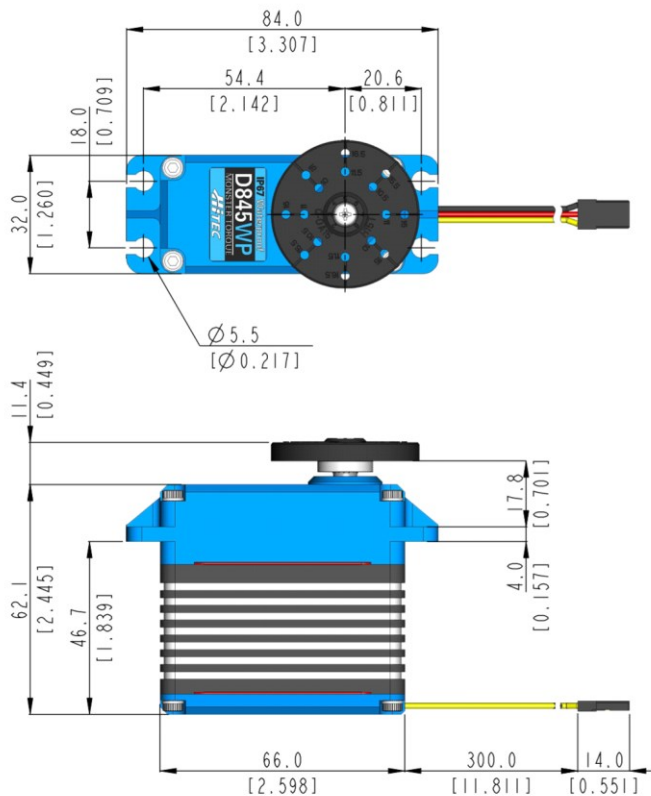

1:2 scale (Unit : mm[inch])

- This product should not be used directly on the human body for medical purposes.
- This product should not be used for war weapons.
- All specifications are subject to change without notice.

