

# HS-5625MG General Specification.

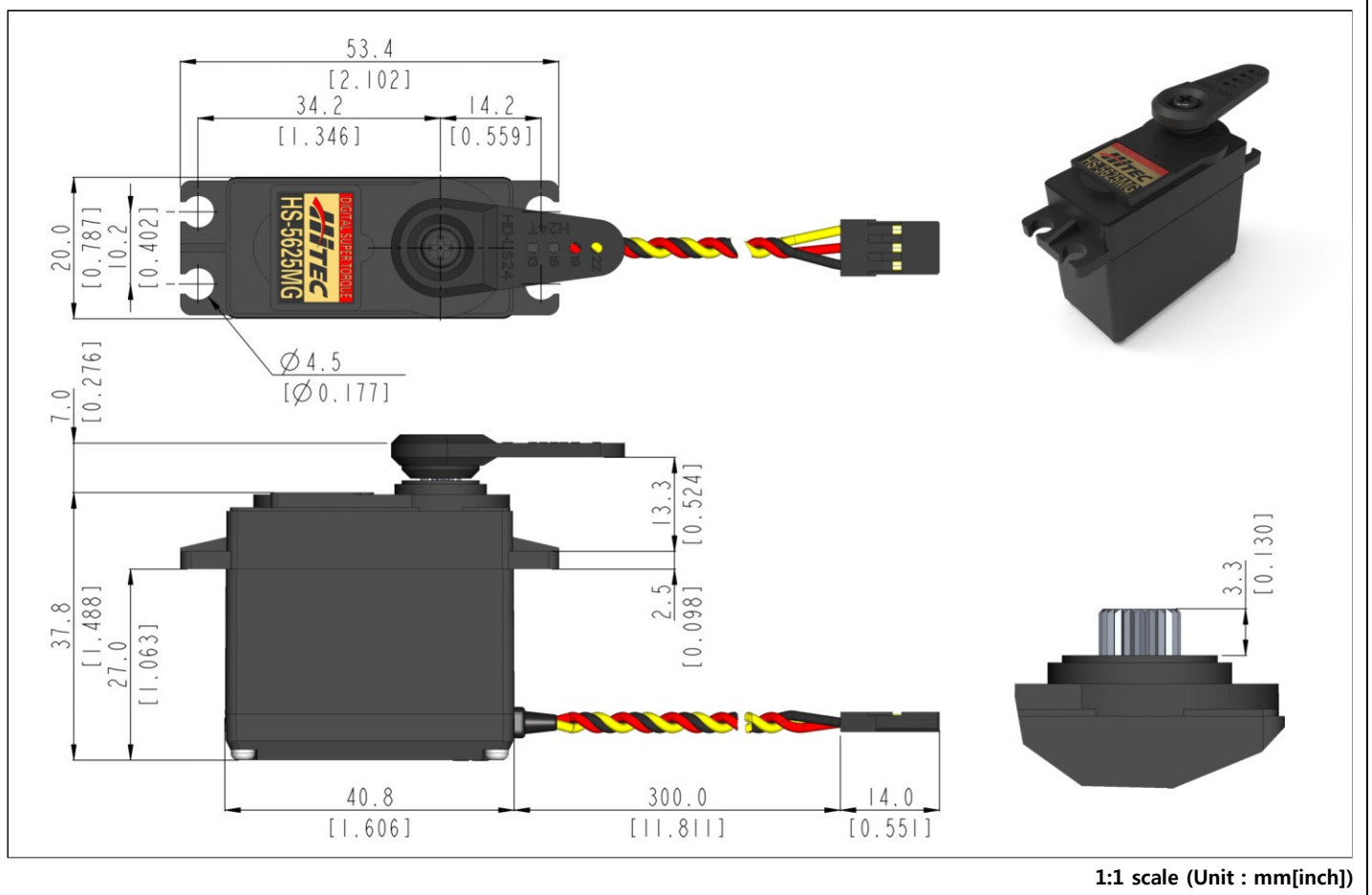

Control System	PWM			-
Position Sensor Type	Contact Analog Potentiometer			-
Motor Type	Cored Metal Brush			At the Max voltage, it is recommended to be used only for a short time duration.
Operating Voltage Range	3.5 ~ 8.4V			
Voltage	4.8V	6.0V	-	At 25°C(±10%), 45%RH(±10%) <u>measurement environment</u>
No Load Speed	0.17sec/60°	0.14sec/60°	-	
Stall Torque	7.9kgf-cm (109.7 oz-in)	9.4kgf-cm (130.5 oz-in)	-	
Peak Efficiency Torque	1.6kgf-cm (22.2 oz-in)	1.9kgf-cm (26.4 oz-in)	-	
Standing Current	3mA	3mA	-	
No Load Running Current	250mA	300mA	-	
Stall Current	1,700mA	2,100mA	-	
Deadband	1μs	1μs	-	
Operating Travel	Default: ±60°, Programmable: Max 175° / Pulse Width: 900~2100μs(Center:1500μs)			
Continuous Rotation	n/a			
Operating Temperature Range	-20°C ~ +60°C (-4°F ~ +140°F)			-
Storage Temperature Range	-30°C ~ +80°C (-22°F ~ +176°F)			-
Connector Wire Length	300mm (11.811inch)			 <ul style="list-style-type: none"> <li>1. SIGNAL</li> <li>2. VCC</li> <li>3. GND</li> </ul>
Connector Wire Gauge	22AWG			
Dimensions	40.8mm x 20.0mm x 37.8mm (1.598inch x 0.780inch x 1.488inch)			General Tolerance ±0.1mm
Weight	60.0g (1.947oz)			Excluding the weight of Horn
Bearing Type	2 Ball Bearing			-
Case Material	Engineering Plastic			-
Gear Material	1 Metal-Plastic & 3 Metal Gears			-
Gear Train Backlash	Max 0.5°			-
Horn Gear Spline	24T(Ø6)			-
IP-Rating	IP4X			-
Servo Amplifier Type	8bit Programmable Digital			-



- This product should not be used directly on the human body for medical purposes.
- This product should not be used for war weapons.
- All specifications are subject to change without notice.

