

HS-5646WP General Specification.

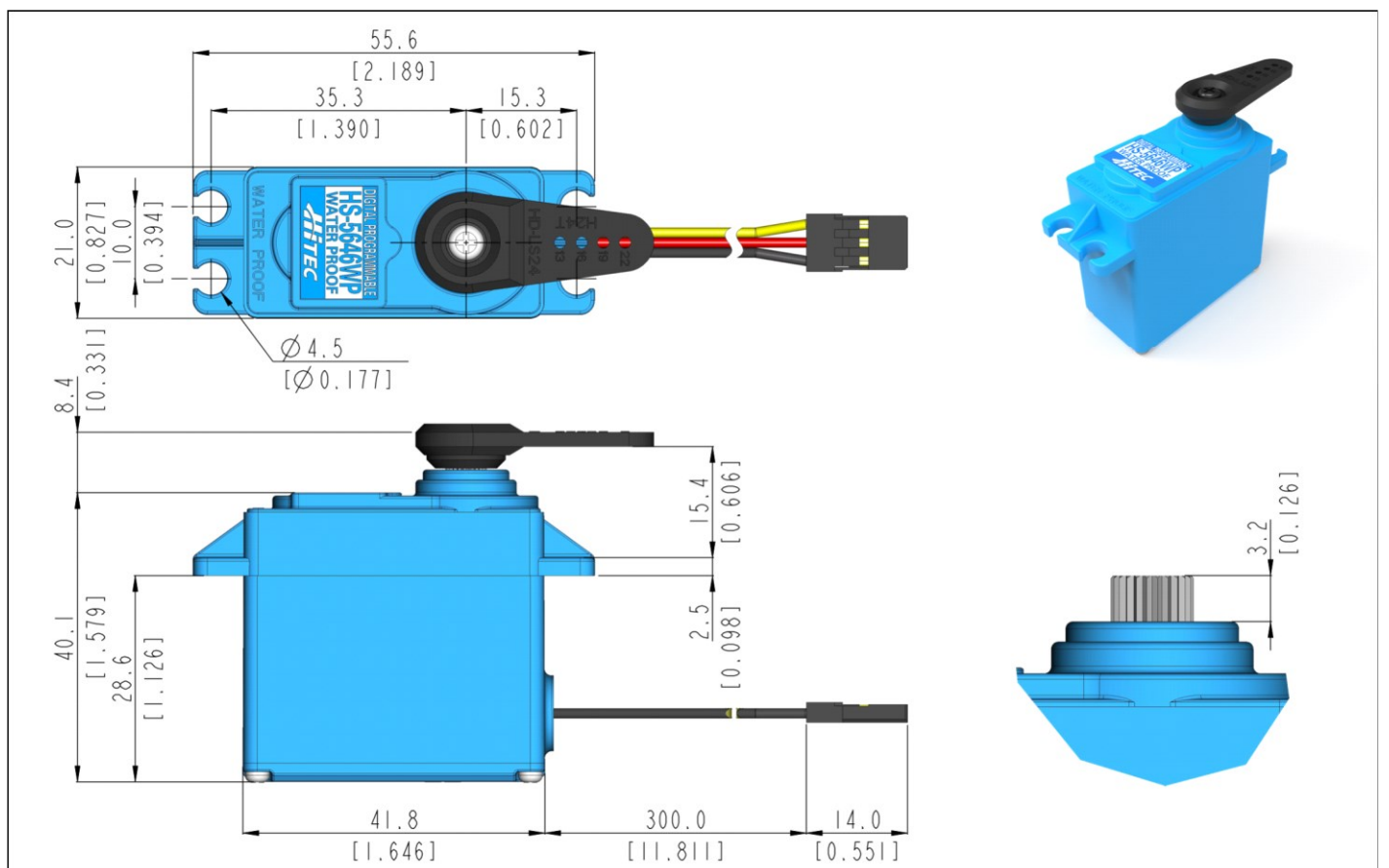

Control System	PWM		-
Position Sensor Type	Contact Analog Potentiometer		-
Motor Type	Cored Metal Brush		At the Max voltage, it is recommended to be used only for a short time duration.
Operating Voltage Range	3.5 ~ 8.4V		
Voltage	-	6.0V	7.4V
No Load Speed	-	0.20sec/60°	0.18sec/60°
Stall Torque	-	11.3kgf-cm (156.9 oz-in)	12.9kgf-cm (179.1 oz-in)
Peak Efficiency Torque	-	2.3kgf-cm (31.9 oz-in)	2.6kgf-cm (36.1 oz-in)
Standing Current	-	5mA	5mA
No Load Running Current	-	270mA	330mA
Stall Current	-	1,670mA	2,100mA
Deadband	-	4μs	4μs
Operating Travel	Default: ±60°, Programmable: Max 175° / Pulse Width: 900~2100μs(Center:1500μs)		At 25°C(±10%), 45%RH(±10%) <u>measurement environment</u>
Continuous Rotation	n/a		
Operating Temperature Range	-20°C ~ +60°C (-4°F ~ +140°F)		
Storage Temperature Range	-30°C ~ +80°C (-22°F ~ +176°F)		
Connector Wire Length	300mm (11.811inch)		
Connector Wire Gauge	22AWG		
Dimensions	41.8mm x 21.0mm x 40.1mm (1.646inch x 0.827inch x 1.579inch)		
Weight	61.0g (2.152oz)		
Bearing Type	2 Ball Bearing		
Case Material	Engineering Plastic		
Gear Material	1 Metal-Plastic & 3 Metal Gears		
Gear Train Backlash	Max 0.5°		
Horn Gear Spline	24T(Ø6)		
IP-Rating	IP67		
Servo Amplifier Type	8bit Programmable Digital		



1:1 scale (Unit : mm[inch])

- This product should not be used directly on the human body for medical purposes.
- This product should not be used for war weapons.
- All specifications are subject to change without notice.

