

HS-77BB General Specification.

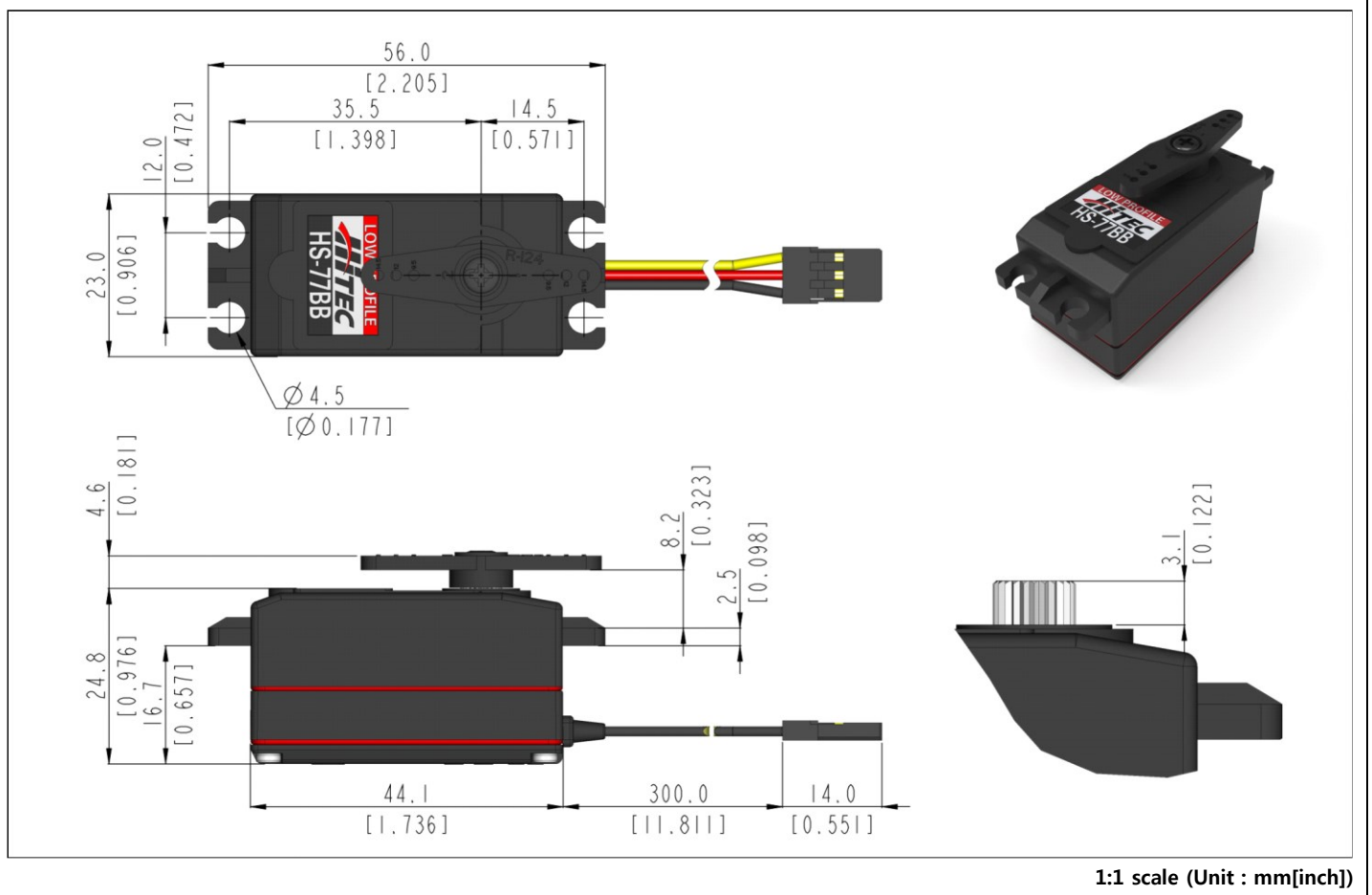

Control System	PWM			-
Position Sensor Type	Contact Analog Potentiometer			-
Motor Type	Cored Metal Brush			At 25°C(±10%), 45%RH(±10%) <u>measurement environment</u>
Operating Voltage Range	4.8V			
Voltage	4.8V	-	-	
No Load Speed	0.18sec/60°	-	-	
Stall Torque	4.4kgf-cm (61.1 oz-in)	-	-	
Peak Efficiency Torque	0.9kgf-cm (12.5 oz-in)	-	-	
Standing Current	8mA	-	-	
No Load Running Current	250mA	-	-	
Stall Current	-	-	-	
Deadband	8μs	-	-	
Operating Travel	Default: ±67.5°, Non-programmable / Pulse Width: 900~2100μs(Center:1500μs)			-
Continuous Rotation	n/a			-
Operating Temperature Range	-20°C ~ +60°C (-4°F ~ +140°F)			-
Storage Temperature Range	-30°C ~ +80°C (-22°F ~ +176°F)			-
Connector Wire Length	300mm (11.811inch)			
Connector Wire Gauge	24AWG			
Dimensions	44.1mm x 23.0mm x 24.8mm (1.736inch x 0.906inch x 0.976inch)			General Tolerance ±0.1mm
Weight	35.0g (1.235oz)			Excluding the weight of Horn
Bearing Type	2 Ball Bearing			-
Case Material	Engineering Plastic			-
Gear Material	5 Resin Gears			-
Gear Train Backlash	Max 0.5°			-
Horn Gear Spline	24T(Ø6)			-
IP-Rating	IP54			-
Servo Amplifier Type	Analog Controller			-



- This product should not be used directly on the human body for medical purposes.
- This product should not be used for war weapons.
- All specifications are subject to change without notice.

