

HS-7955TG General Specification.

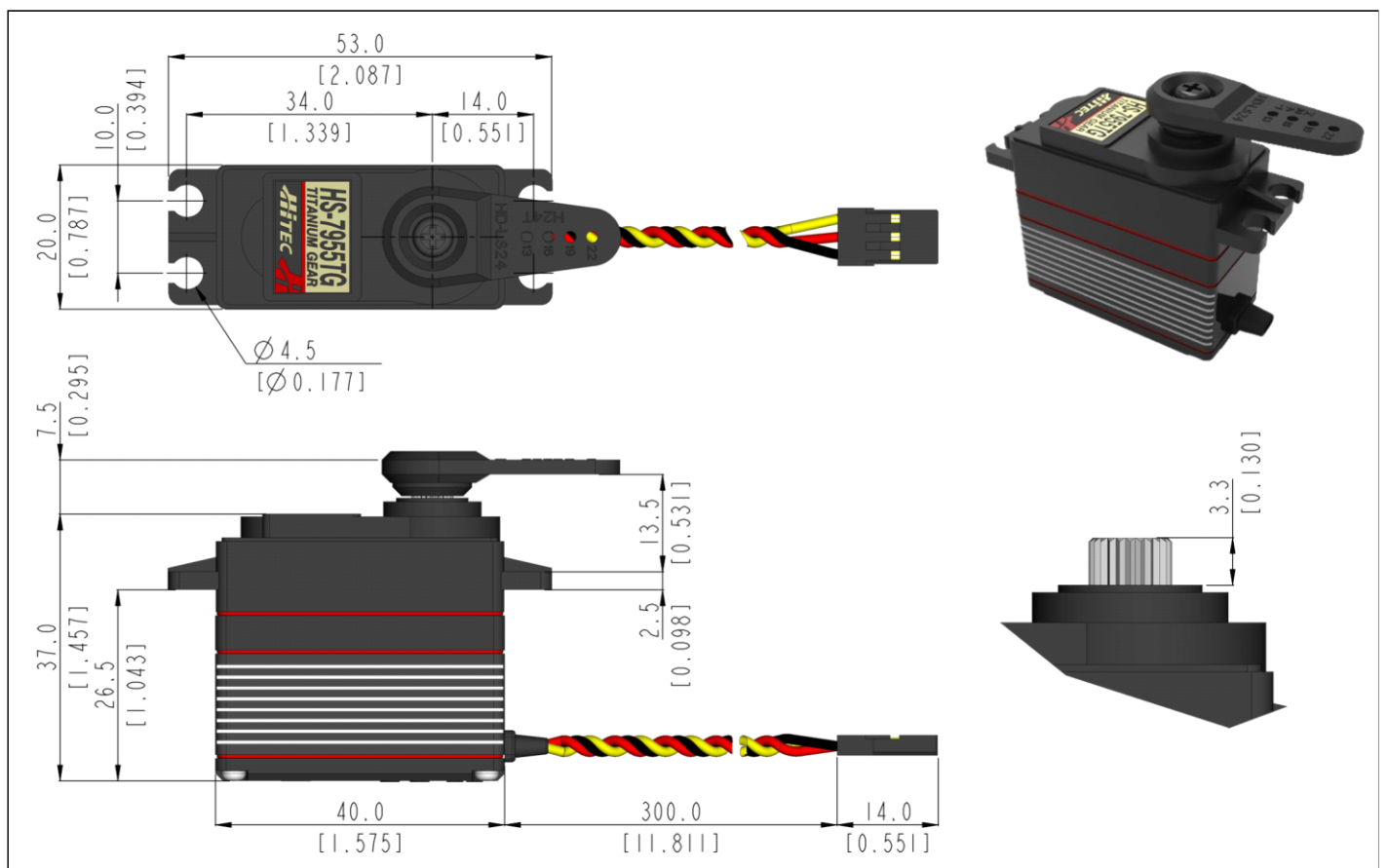

Control System	PWM			-	
Position Sensor Type	Contact Analog Potentiometer			-	
Motor Type	Coreless			At the Max voltage, it is recommended to be used only for a short time duration.	
Operating Voltage Range	3.5 ~ 8.4V				
Voltage	4.8V	6.0V	-	At 25°C(±10%), 45%RH(±10%) <u>measurement environment</u>	
No Load Speed	0.19sec/60°	0.15sec/60°	-		
Stall Torque	18.0kgf-cm (250.0 oz-in)	24.0kgf-cm (333.3 oz-in)	-		
Peak Efficiency Torque	3.6kgf-cm (50.0 oz-in)	4.8kgf-cm (66.7 oz-in)	-		
Standing Current	9mA	9mA	-		
No Load Running Current	220mA	300mA	-		
Stall Current	3,400mA	4,200mA	-		
Deadband	1μs	1μs	-		
Operating Travel	Default: ±60°, Programmable: Max 175° / Pulse Width: 900~2100μs(Center:1500μs)				Based on resolution normal mode
Continuous Rotation	n/a				-
Operating Temperature Range	-20°C ~ +60°C (-4°F ~ +140°F)			-	
Storage Temperature Range	-30°C ~ +80°C (-22°F ~ +176°F)			-	
Connector Wire Length	300mm (11.811inch)				
Connector Wire Gauge	22AWG				
Dimensions	40.0mm x 20.0mm x 37.0mm (1.575inch x 0.787inch x 1.457inch)			General Tolerance ±0.1mm	
Weight	65.0g (2.293oz)			Excluding the weight of Horn	
Bearing Type	2 Ball Bearing			-	
Case Material	Engineering Plastic & Aluminum Heat Sink			-	
Gear Material	1 Metal-Plastic & 3 Titanium Alloy Gears			-	
Gear Train Backlash	Max 0.5°			-	
Horn Gear Spline	24T(Ø6)			-	
IP-Rating	IP54			-	
Servo Amplifier Type	8bit Programmable Digital			-	



1:1 scale (Unit : mm[inch])

- This product should not be used directly on the human body for medical purposes.
- This product should not be used for war weapons.
- All specifications are subject to change without notice.

