

HSB-9381TH General Specification.

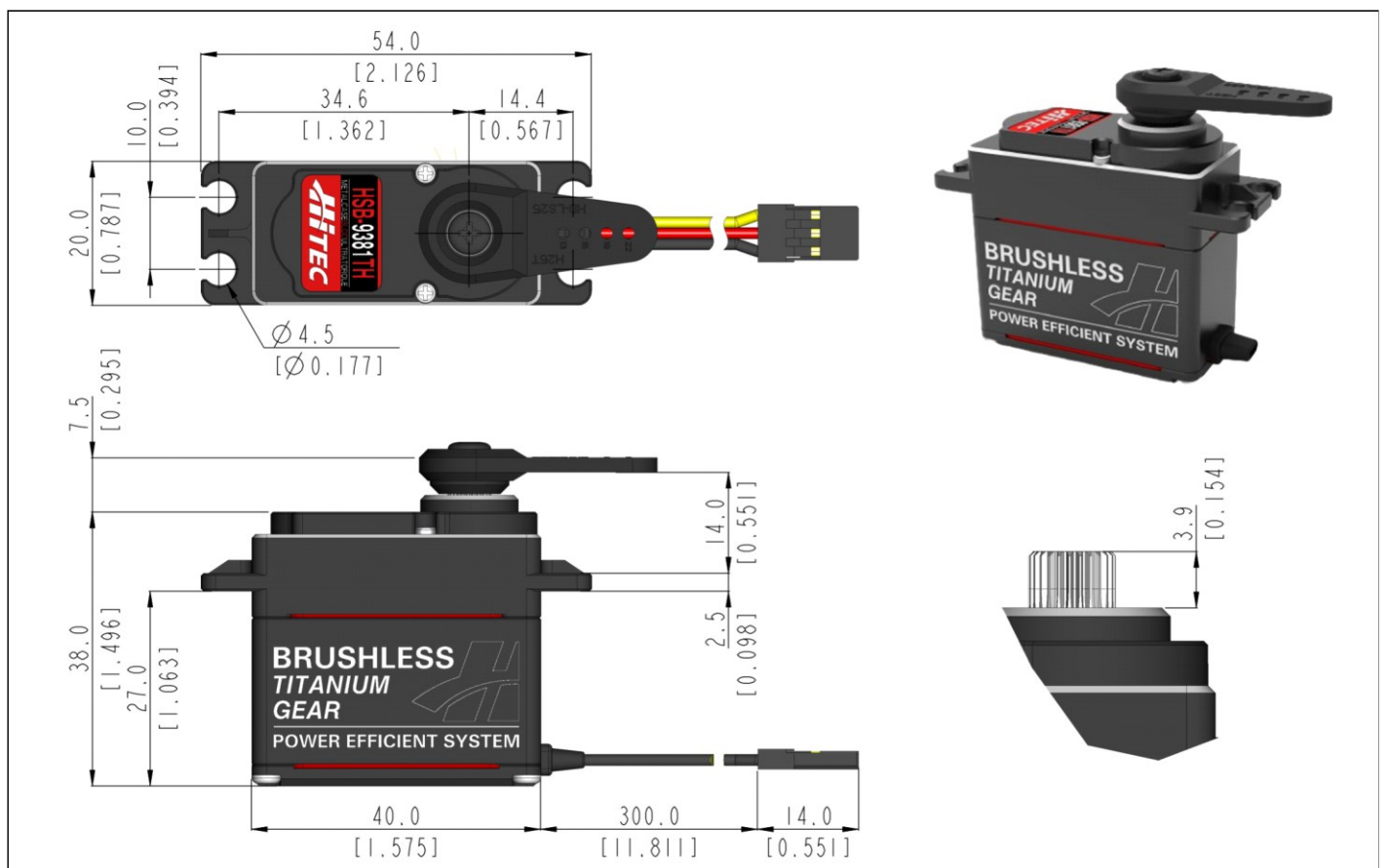

| | | | |
|-----------------------------|--|--------------------------|---|
| Control System | PWM | | - |
| Position Sensor Type | Contact Analog Potentiometer | | - |
| Motor Type | BLDC | | At the Max voltage, it is recommended to be used only for a short time duration. |
| Operating Voltage Range | 4.0 ~ 8.4V | | |
| Voltage | - | 6.0V | 7.4V |
| No Load Speed | - | 0.17sec/60° | 0.14sec/60° |
| Stall Torque | - | 34.0kgf-cm (472.2 oz-in) | 34.0kgf-cm (472.2 oz-in) |
| Peak Efficiency Torque | - | 6.8kgf-cm (94.4 oz-in) | 6.8kgf-cm (94.4 oz-in) |
| Standing Current | - | 27mA | 27mA |
| No Load Running Current | - | 250mA | 250mA |
| Stall Current | - | 2,700mA | 2,100mA |
| Deadband | - | 1μs | 1μs |
| Operating Travel | Default: ±60°, Programmable: Max 160° / Pulse Width: 900~2100μs(Center:1500μs) | | - |
| Continuous Rotation | n/a | | - |
| Operating Temperature Range | -20°C ~ +60°C (-4°F ~ +140°F) | | - |
| Storage Temperature Range | -30°C ~ +80°C (-22°F ~ +176°F) | | - |
| Connector Wire Length | 300mm (11.811inch) | |  |
| Connector Wire Gauge | 20AWG | | |
| Dimensions | 40.0mm x 20.0mm x 38.0mm (1.575inch x 0.787inch x 1.496inch) | | General Tolerance ±0.1mm |
| Weight | 79.0g (2.787oz) | | Excluding the weight of Horn |
| Bearing Type | 2 Ball Bearing | | - |
| Case Material | Aluminum Alloy | | - |
| Gear Material | 1 Metal-Plastic & 3 Titanium Alloy Gears | | - |
| Gear Train Backlash | Max 0.5° | | - |
| Horn Gear Spline | 25T(Ø6) | | - |
| IP-Rating | IP54 | | - |
| Servo Amplifier Type | 16bit Programmable Digital | | - |



1:1 scale (Unit : mm[inch])

- This product should not be used directly on the human body for medical purposes.
- This product should not be used for war weapons.
- All specifications are subject to change without notice.

