

# HSR-2645CR General Specification.

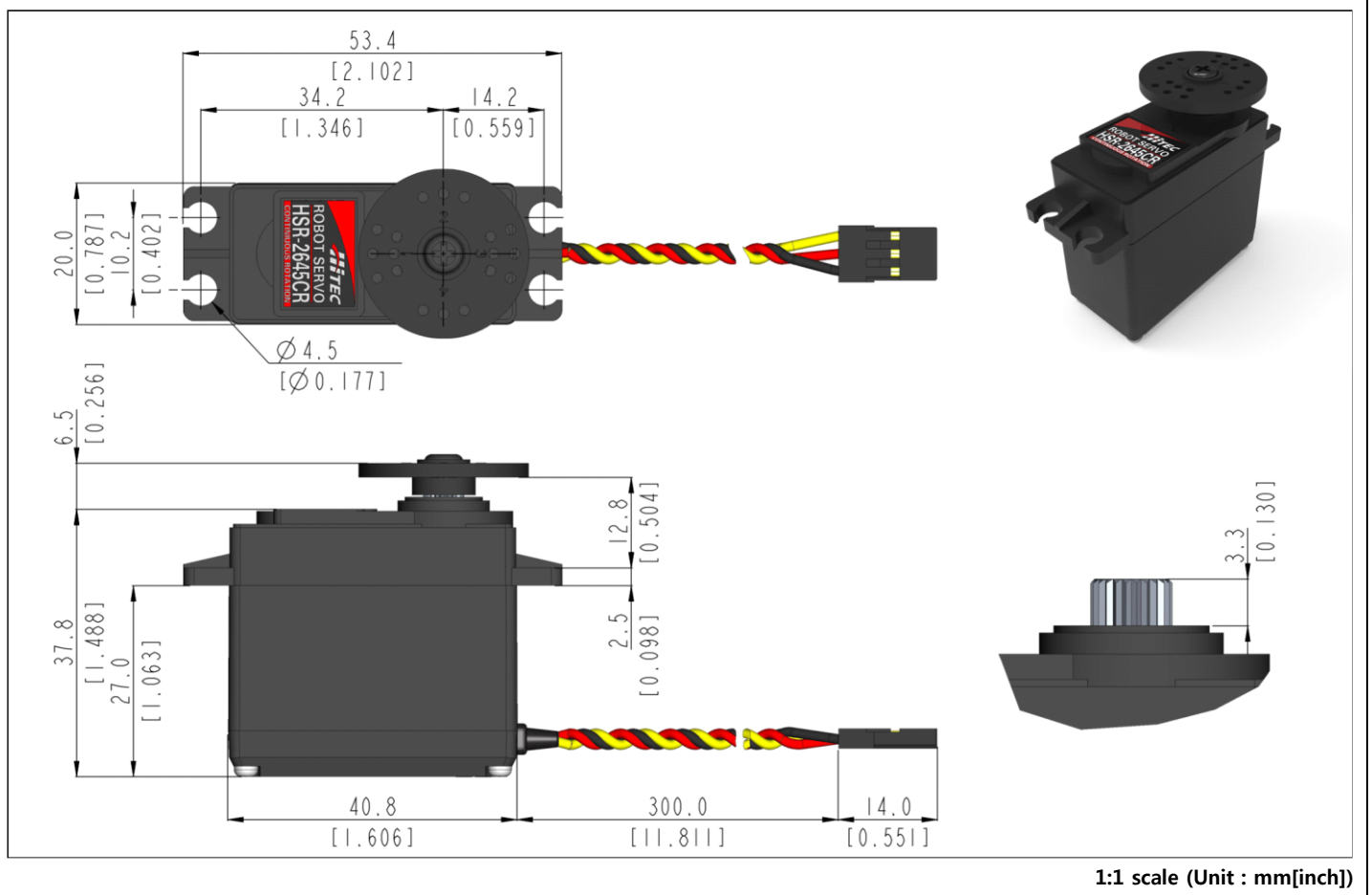

Control System	PWM			-
Position Sensor Type	-			-
Motor Type	Cored Carbon Brush			At the Max voltage, it is recommended to be used only for a short time duration.
Operating Voltage Range	3.5 ~ 8.4V			
Voltage	4.8V	6.0V	7.4V	At 25°C(±10%), 45%RH(±10%) <u>measurement environment</u>
No Load Speed	46.0RPM	58.0RPM	72.0RPM	
Stall Torque	8.0kgf-cm (111.1 oz-in)	10.0kgf-cm (138.9 oz-in)	12.0kgf-cm (166.6 oz-in)	
Peak Efficiency Torque	1.6kgf-cm (22.2 oz-in)	2.0kgf-cm (27.8 oz-in)	2.4kgf-cm (33.3 oz-in)	
Standing Current	3mA	3mA	3mA	
No Load Running Current	110mA	120mA	140mA	
Stall Current	1,700mA	2,000mA	2,400mA	
Deadband	-	-	-	
Operating Travel	Default: Continuous Rotation / Pulse Width: 900~2100µs(Center:1500µs)			
Continuous Rotation	Able			-
Operating Temperature Range	-20°C ~ +60°C (-4°F ~ +140°F)			-
Storage Temperature Range	-30°C ~ +80°C (-22°F ~ +176°F)			-
Connector Wire Length	300mm (11.811inch)			
Connector Wire Gauge	22AWG			
Dimensions	40.8mm x 20.0mm x 37.8mm (1.606inch x 0.787inch x 1.488inch)			General Tolerance ±0.1mm
Weight	53.0g (1.870oz)			Excluding the weight of Horn
Bearing Type	2 Ball Bearing			-
Case Material	Engineering Plastic			-
Gear Material	1 Metal-Plastic & 3 Metal Gears			-
Gear Train Backlash	Max 0.5°			-
Horn Gear Spline	24T(Ø6)			-
IP-Rating	IP4X			-
Servo Amplifier Type	8bit programmable Digital			-



- This product should not be used directly on the human body for medical purposes.
- This product should not be used for war weapons.
- All specifications are subject to change without notice.

