

# MD250MW General Specification.

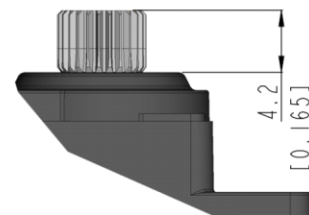

Control System	PWM/TTL(Half Duplex)			-
Position Sensor Type	Contactless Magnetic Encoder			-
Motor Type	Cored Carbon Brush			At the Max voltage, it is recommended to be used only for a short time duration.
Operating Voltage Range	3.5 ~ 8.4V			
Voltage	4.8V	6.0V	7.4V	At 25°C(±10%), 45%RH(±10%) <u>measurement environment</u>
No Load Speed	0.20sec/60°	0.16sec/60°	0.13sec/60°	
Stall Torque	4.9kgf-cm (68.05oz-in)	6.1kgf-cm (84.71oz-in)	7.5kgf-cm (104.16oz-in)	
Peak Efficiency Torque	1.0kgf-cm (13.89oz-in)	1.2kgf-cm (16.66oz-in)	1.5kgf-cm (20.83oz-in)	
Standing Current	40mA	40mA	40mA	
No Load Running Current	110mA	150mA	190mA	
Stall Current	1,000mA	1,300mA	1,600mA	
Deadband	2μs	2μs	2μs	
Operating Travel	Default: ±60°, Programmable: Max 320° / Pulse Width: 900~2100μs(Center:1500μs)			-
Continuous Rotation	n/a			-
Operating Temperature Range	-20°C ~ +60°C (-4°F ~ +140°F)			-
Storage Temperature Range	-30°C ~ +80°C (-22°F ~ +176°F)			-
Connector Wire Length	300mm (11.811inch)			
Connector Wire Gauge	22AWG			
Dimensions	35.4mm x 15.0mm x 32.0mm (1.394inch x 0.591inch x 1.260inch)			General Tolerance ±0.1mm
Weight	38.3g (1.351oz)			Excluding the weight of Horn
Bearing Type	2 Ball Bearing			-
Case Material	Engineering Plastic			-
Gear Material	1 Metal-Plastic & 4 Steel Gears			-
Gear Train Backlash	Max 0.5°			-
Horn Gear Spline	25T(Ø6)			-
IP-Rating	IP4X			-
Servo Amplifier Type	32bit programmable Digital			-

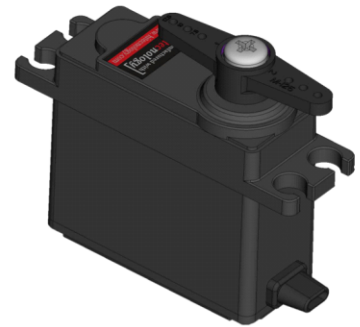
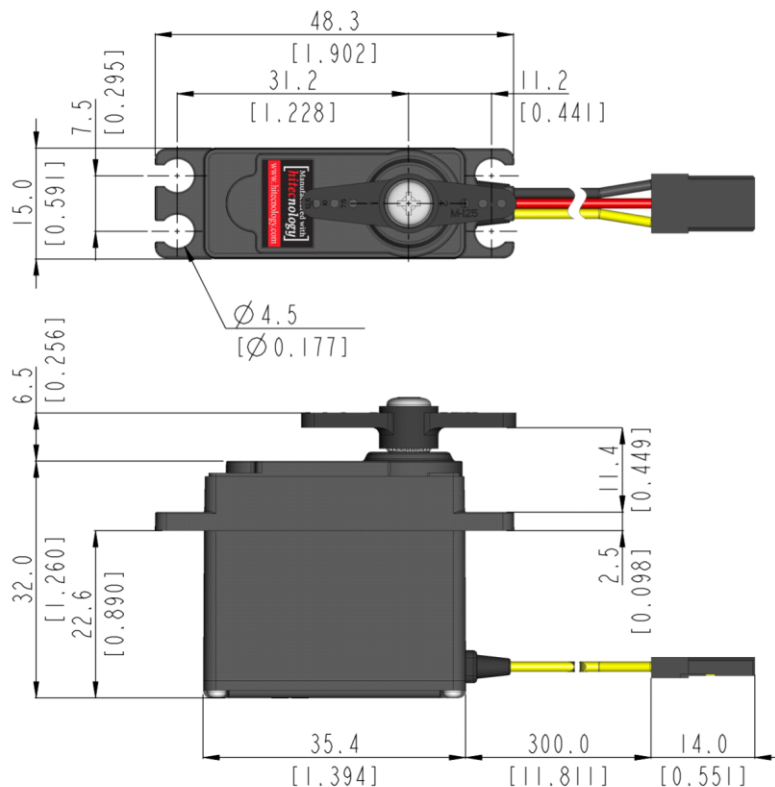

1:1 scale (Unit : mm[inch])

- This product should not be used directly on the human body for medical purposes.
- This product should not be used for war weapons.
- All specifications are subject to change without notice.
- Be careful as strong magnetic fields may cause malfunction of the product.

