

MD485HW General Specification.

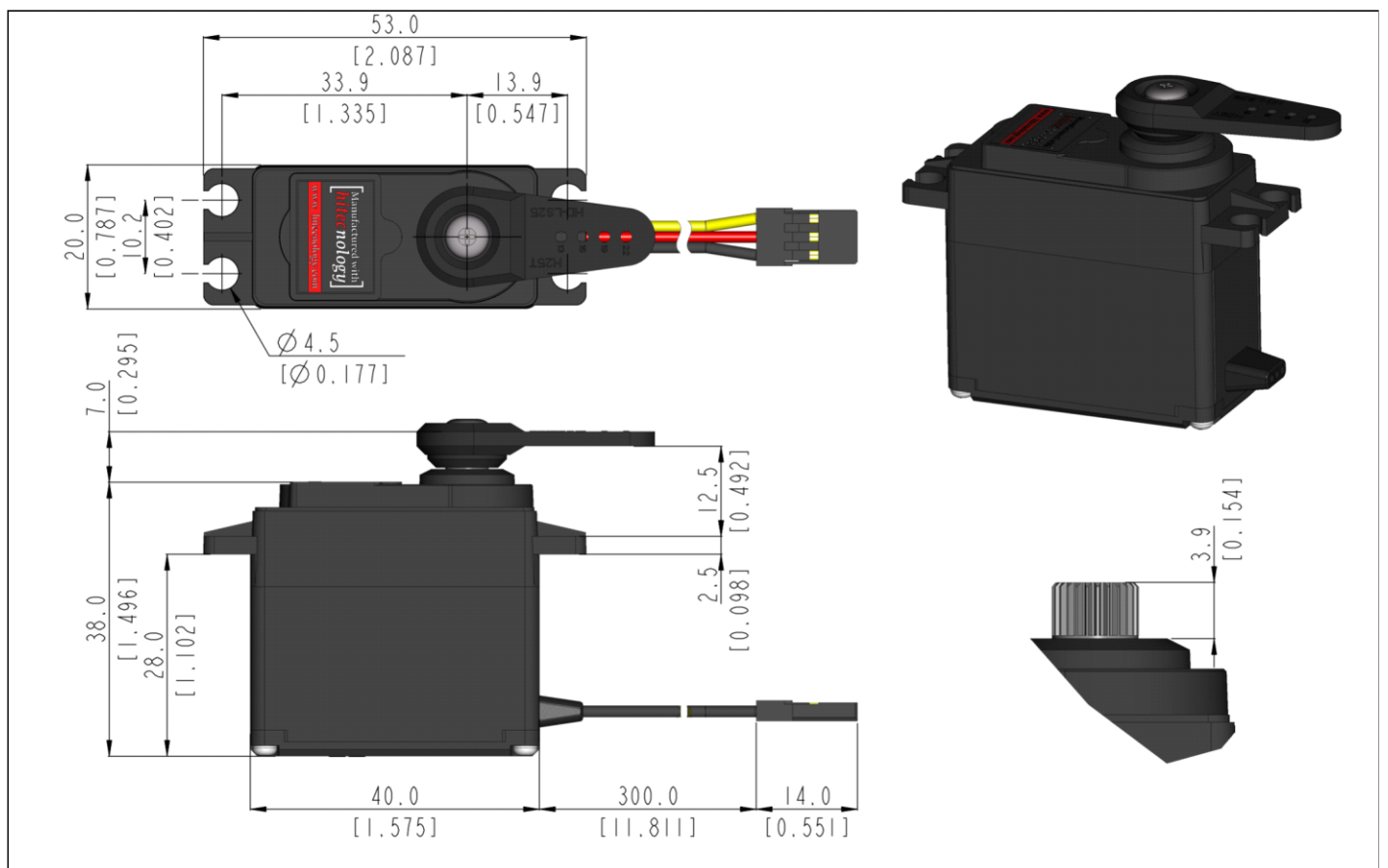

Control System	PWM/TTL(Half Duplex)			-
Position Sensor Type	Contactless Magnetic Encoder			-
Motor Type	Cored Carbon Brush			At the Max voltage, it is recommended to be used only for a short time duration.
Operating Voltage Range	3.5 ~ 8.4V			
Voltage	4.8V	6.0V	7.4V	At 25°C(±10%), 45%RH(±10%) <u>measurement environment</u>
No Load Speed	0.20sec/60°	0.17sec/60°	0.15sec/60°	
Stall Torque	4.8kgf-cm (66.66oz-in)	6.0kgf-cm (83.32oz-in)	7.4kgf-cm (102.77oz-in)	
Peak Efficiency Torque	1.0kgf-cm (13.89oz-in)	1.2kgf-cm (16.66oz-in)	1.5kgf-cm (20.83oz-in)	
Standing Current	30mA	30mA	30mA	
No Load Running Current	250mA	280mA	320mA	
Stall Current	1,000mA	1,200mA	1,500mA	
Deadband	2μs	2μs	2μs	
Operating Travel	Default: ±60°, Programmable: Max 320° / Pulse Width: 900~2100μs(Center:1500μs)			-
Continuous Rotation	n/a			-
Operating Temperature Range	-20°C ~ +60°C (-4°F ~ +140°F)			-
Storage Temperature Range	-30°C ~ +80°C (-22°F ~ +176°F)			-
Connector Wire Length	300mm (11.811inch)			 <ul style="list-style-type: none"> 1. SIGNAL 2. VCC 3. GND
Connector Wire Gauge	24AWG			
Dimensions	39.8mm x 20.0mm x 38.0mm (1.567inch x 0.787inch x 1.496inch)			General Tolerance ±0.1mm
Weight	43.3g (1.527oz)			Excluding the weight of Horn
Bearing Type	2 Ball Bearing			-
Case Material	Engineering Plastic			-
Gear Material	4 Heavy Duty Resin Gears			-
Gear Train Backlash	Max 0.5°			-
Horn Gear Spline	25T(Ø6)			-
IP-Rating	IP4X			-
Servo Amplifier Type	32bit programmable Digital			-



1:1 scale (Unit : mm[inch])

- This product should not be used directly on the human body for medical purposes.
- This product should not be used for war weapons.
- All specifications are subject to change without notice.
- Be careful as strong magnetic fields may cause malfunction of the product.

